



# OPERATION AND MAINTENANCE



FOLDING MOTORBIKE

# Di Blasi

Mod. R7-E



# INDEX

Brakes (adjustments)	5.3
Cable (throttle)	5.4
Diagnosis	8
Expanding pulley (disassembling)	6.2
Folding	3
Fuel	4.2
Handlebar hinge (adjustment)	5.2
Handlebar hook (adjustment)	5.1
Headlamp (adjustment)	5.6
Horn	4.6
Idling	5.5
Lights	4.5
Magnetowheel	5.8
Reduction unit (disassembling)	6.1
Riding	4.4
Running in	4.1
Servicing	5.9 - 7
Spark plug	5.7
Technical specifications	1
Tyre pressure	4.3
Turn signal lamps	4.7
Unfolding	2
Wheels (disassembling)	6.1 - 6.3
Wiring diagram	5.10

# Notice

Pictures and drawings of this manual have the sole aim to illustrate the operations described herein: however, they may not correspond exactly to your vehicle.

# 1. SPECIFICATIONS

## 6 Dimensions

### - Open:

Overall length	128 cm (50“)
Wheel base	93 cm (37“)
Width	58 cm (23“)

### - Folded:

Length	78 cm (30“)
Width	36 cm (14“)
Height	61 cm (24“)

6 Unladen mass	32 kg (69 Lbs)
6 Rim size (front & rear)	5“
6 Tyre size (front & rear)	4.00 - 5“
6 Brakes drum diameter	90 mm (front & rear)
6 Electrical equipment	12V - 65W
6 Tank capacity	3 litres (3 quarts)
6 Fuel consumption	50 km/lt (approx) (130 mls per gallon)
6 Maximum speed	50 km/h (30 mph)
6 Seating capacity	1

## 6 Engine

- manufacturer & model	DI BLASI M1
- single cylinder, two stroke	
- bore	39 mm
- stroke	41,8 mm
- cylinder capacity	49.9 cc
- compression ratio	8,65 : 1
- maximum power	0,92 KW at 3700 RPM
- maximum torque	2,56 Nm at 3000 RPM
- spark plug	BOSCH W7A or AC43F or N.G.K. B6HS
- carburetor	DELL'ORTO SHA 14-12 main jet size: 53 choke tube: 12 mm
- fuel	regular gasoline with 2% of 2 stroke oil
- primary drive	V-Belt variator ratios: min 1:1,577 max 1:3,736
- secondary drive	timing belt ratio 22/102 = 1 : 4,636
- starting	foot kick starter

## 2. TO UNFOLD THE VEHICLE



Fig. 1

When the vehicle is folded, it stands up alone.



Fig. 2

Rotate the handlebar on the stem hinge until it is locked by the hook.

**Important Caution:** make sure that both springs which pull the hook are functioning properly and that the hook itself is properly positioned (sec.5.1). When rotating the handlebar, do not turn the wheel, because the muffler pipe is still in the way. .



Fig. 3

Holding the handlebar with the left hand, with the right hand pull and then backwards the rear edge of the saddle until...



Fig. 4

... the frame is locked automatically by the hook located on its right side under the saddle. Place the vehicle on its stand. Unfold the foot rest. Unfold the rearview mirror. Before riding, read sec. 4.4.

### 3. TO FOLD THE VEHICLE



Fig

Close the fuel tap (A-fig.9) by turning the lever to OFF (pointing backward) . Closing of the tank air vent hole is automatic. If you need to store the moped on it's side, run the engine until it consumes all the fuel in the carburetor reservoir.



Fig

Fold the rearview mirror.  
Push the vehicle off its stand.  
Turn the steering fully to the right.  
Release the frame hook located on the right side under the saddle and .....



Fig.

.....push the rear edge of the saddle forward until it is almost at the same level with the filler cap.  
Unhook the handlebar and lower it.



Fig. 8

Fold the foot rest.  
The vehicle stands up alone.

# 4 OPERATING INSTRUCTIONS

## 4.1 Running-in

During the first 500 km (300 mls), use a mixture of regular gasoline with 4% two stroke oil and do not operate at more than 3/4 throttle. At about 500 km (300 mls) check all bolts and nuts for proper tightness and tighten the cylinder head nuts at 10 Nm torque.

## 4.2 Fuel

After the first 500 km (300 mls) use a mixture of regular gasoline with 2% two stroke oil.

**CAUTION:** an improper mixture or just fuel without oil will cause damages and voids all warranties.

## 4.3 Tyre pressure

Front: 1,2 atm (18 psi)

Rear: 1,8 atm (26 psi)

## 4.4 Riding

- 6 Place the vehicle on its stand and make sure that the rear wheel is rised from the ground.
- 6 Open the fuel tap placed under the tank turning the lever straight down to ON or straight up to reserve (fig.9).
- 6 If the engine is cold, push down the choke lever located on the carburetor (A-fig.10).
- 6 In USA mpeds only: move the red switch (S-fig. 12 US) located on the right side of the handlebar into RUN position.

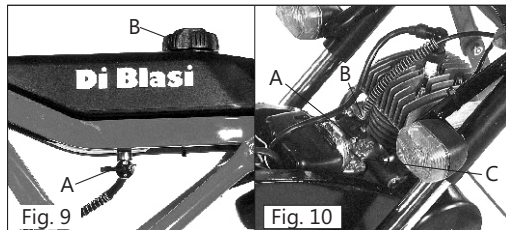

- 6 Open the throttle slightly, by twisting the right handlebar grip (B-fig.12).
- 6 Start the engine by pushing down the kick starter lever with the foot.
- 6 A few seconds after that the engine as started, release the choke to its open position by opening the throttle completely and immediately closing it. Prolonged operation with the choke on will cause spark plug fouling. Use caution to insure that the vehicle is on its stand and apply the front brake while the throttle is opened completely.
- 6 Get on the vehicle assuming the riding position.
- 6 With the throttle in the closed position, apply the rear brake before pushing the vehicle off its stand.
- 6 Once started, the vehicle is driven at the desired speed solely by use of the twist grip throttle (B-fig12)



6 To slow down, close the throttle and, if necessary, apply the brakes.

6 The vehicle is equipped with two brakes. The front wheel brake is controlled by the lever on the right side of the handlebar (C-fig 12). The rear wheel brake is controlled by the lever on the left side of the handlebar (D-fig.12). Under normal stopping conditions, use the rear brake only. Use the front brake only if necessary and in conjunction with the rear brake: in any case very softly and with extreme caution. Hard, sudden use of the front brake can be very dangerous.

6 With the throttle in the closed position, the engine will run while the vehicle is stationary.

6 To stop the engine:

- **In European mopeds:** close the throttle and press the red button (S) located on the left side of the handlebar (fig.12 EU).
- **In USA mopeds:** close the throttle and move the red switch (S), located on the right side of the handlebar, into STOP position (fig.12 US).

#### 4.5 Lights

The switch for the lights is located on the left side of the handlebar (L-fig.12)

6 **In European mopeds:** the three positions of the switch correspond to: off, low, high beam.

6 **In USA mopeds:** lights are always switched on when engine runs. The three positions of the switch correspond to: low beam, high beam, flashing.

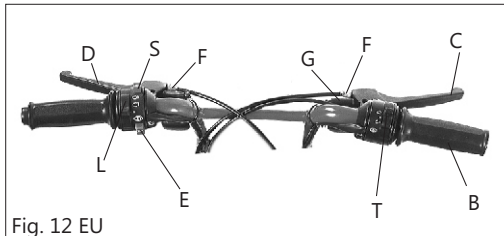

Fig. 12 EU

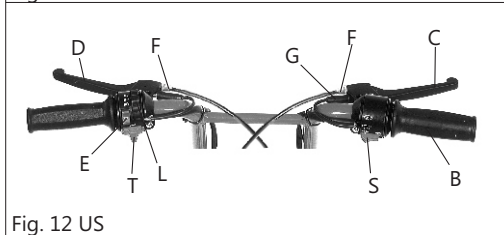

Fig. 12 US

#### 4.6 Horn

The push button for the horn (color blue) is located on the left side of the handlebar (fig.12 - E).

#### 4.7 Turn signal lamps

The switch (T) for the turn signal lamps is located:

6 In European mopeds: on the right of the handlebar (fig.12 EU);

6 In USA mopeds: on the left of the handlebar (fig.12 US);

# 5 CHECKS AND ADJUSTMENTS

## 5.1 Handlebar hook

The locking hook is secured by two springs (A-fig.14). Before riding, be sure that both springs are working properly.

The correct position of the hook is illustrated in fig.14. If the hook goes out of adjustment (as illustrated in fig.13 and 15), readjust as follows:

- 6 loosen the screw (B) for a fraction of turn;
- 6 turn the knurled eccentric ring (C) until the hook assumes the position indicated in fig. 14;
- 6 tighten again the screw (B)

## 5.2 Handlebar hinge

If the handlebar hinge feels loose, tighten the lock nut (A-fig. 16) to take out the slack without overtightening.

The handlebar stem must still swivel reasonable easy.

## 5.3 Brakes

The brakes may be adjusted at the handbrake levers (F-fig. 12) and at the brake backing plate (A-fig.17)

After each adjustment tighten the correspondent nut.

With the brake levers in their normal position, the wheels must turn freely.

To check the brake lining thickness, remove the rubber plugs located in the brake backing plates (B-fig. 17).

## 5.4 Throttle cable

To take up slacks in the throttle cable, adjust device B - fig. 10 or G - fig. 12 .Tighten the lock nut after adjustment.

## 5.5 Idling

To adjust the engine idling speed (fig.10):

increasing: turn the screw C clockwise

decreasing: turn the screw C counterclockwise

## 5.6 Head lamp

The head lamp inclination may be adjusted after loosening the two mounting screws.

## 5.7 Spark plug

The gap of the electrodes should be  $0,3 \div 0,4$  mm. Clean the spark plug with the wire brush located in the tool box.

Tightening torque of the spark plug on the cylinder head: 28 Nm

## 5.8 Magnetowheel

The spark plug ignition is provided by an electronic magnetowheel.

The spark advance is  $22^\circ \div 24^\circ$  corresponding to  $2,30 \div 2,45$  mm before the top dead center.

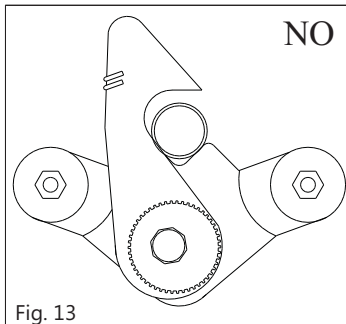

Fig. 13

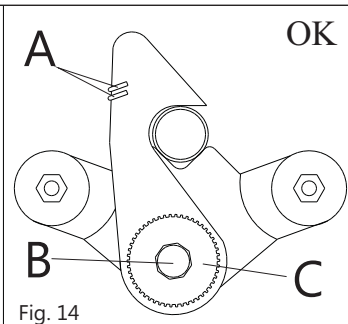

Fig. 14

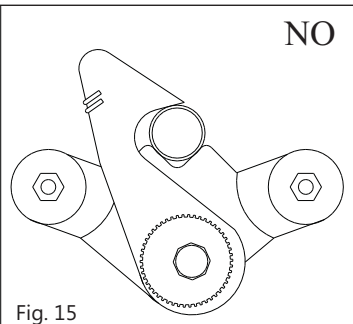

Fig. 15

### 5.9 Nuts and bolts

All nuts and bolts are equipped with locking devices (lock nuts, self locking nuts, lock washers). Nevertheless, check the tightening periodically.

### 5.10 Wiring harness

See electric diagram:

**In the European mopeds:** fig. 22 EU

**In the USA mopeds:** fig. 22 US

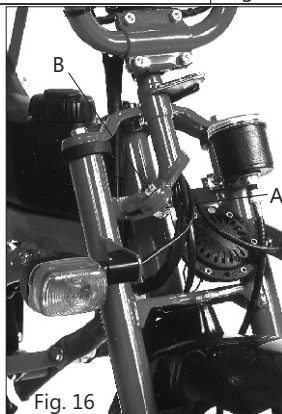

Fig. 16

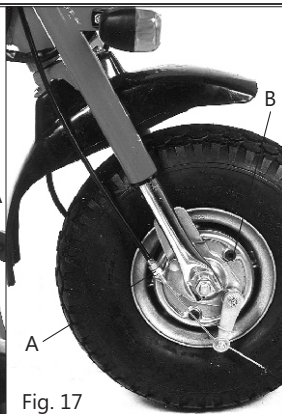

Fig. 17

## 6 DISASSEMBLIES

### 6.1 Rear wheel - reduction unit (fig. 18-19)

- 6 Unscrew the lock nut of the screw (A) and then the screw (A) at the bottom of the left shock absorber.
- 6 Rotate the left shock absorber on its top end so to keep it removed from the belt guard.
- 6 Unscrew the three bolts (B1 - B2 - B3) holding the belt guard.
- 6 Disconnect the brake cable from the brake backing plate on the right hand side of the wheel;
- 6 While pulling forward the reduction unit arm (C), remove the primary belt (D);
- 6 Remove the screw head (G) through the hole (H);
- 6 Unscrew the nuts (L) holding the wheel to the fork;
- 6 Remove the wheel assembly from the fork;
- 6 Disconnect the spring (M) at its end (N);
- 6 Remove the arm (C) from its rotation pin together with the timing belt;
- 6 Remove the tap washer (P), unscrew the four screws (Q) and remove the crown wheel.

For reassembling, the previous steps are to be carried out in on the reverse.

### 6.2 Expanding pulley / clutch (fig.18)

For disassembling:

- 6 Unscrew the three bolts (B1 - B2 - B3) holding the belt guard.
- 6 unscrew screw (T);

For assembling:

- 6 add a drop of loctite (medium grade) in the screw (T)
- 6 tighten the screw (T) with a pneumatic screwdriver or with a socket wrench while holding the magnetowheel

For spare parts order see Fig. 21

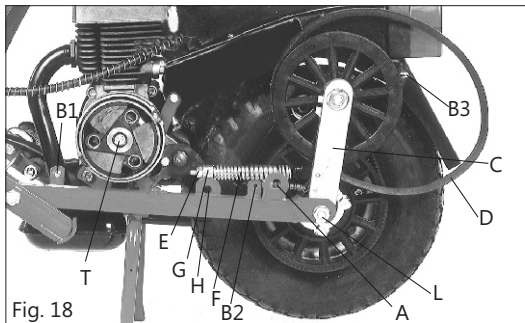

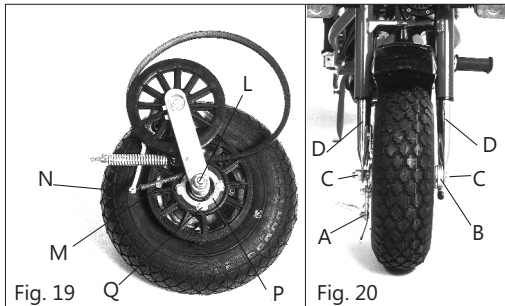

### 6.3 Front wheel (fig.20)

- 6 disconnect the brake cable at the brake backing plate (A);
  - 6 disconnect the speedometer cable at the speedometer drive (B);
  - 6 Unscrew the clamping nuts (C).
- CAUTION:** when reassembling the wheel, do not turn (screwing or unscrewing) the fork tips (D).

## 7. SERVICING

### 7.1 Every 1000 km (600 miles)

- 6 Lubricate with grease the speedometer drive (B-fig.18) through the lubricating nipple.
- 6 Clean the air filter and the carburetor;

### 7.2 Once a year

- 6 Lubricate the cables (brakes, throttle, speedometer) and the frame articulations with a drop of light oil.
- 6 Clean the starting gears and lubricate with grease.
- 6 Replace the rubber fuel line: after one year the rubber tube becomes brittle and cracked and this can cause fire when the engine is hot.

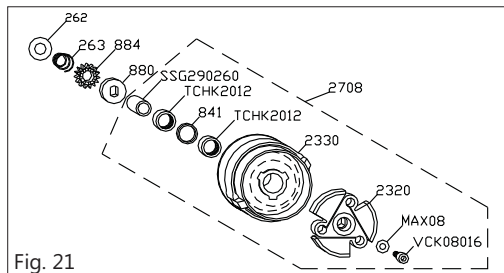

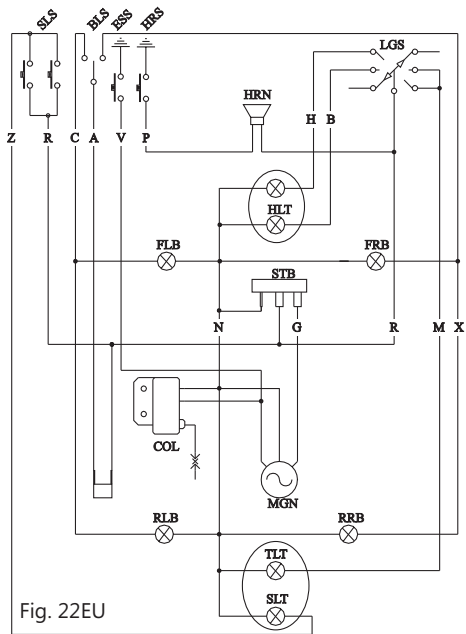

A Orange  
 B White  
 C Blue  
 G Yellow  
 H Gray  
 M Brown  
 N Black  
 P Pink  
 R Red  
 V Green  
 X Yellow-Green  
 Z Violet

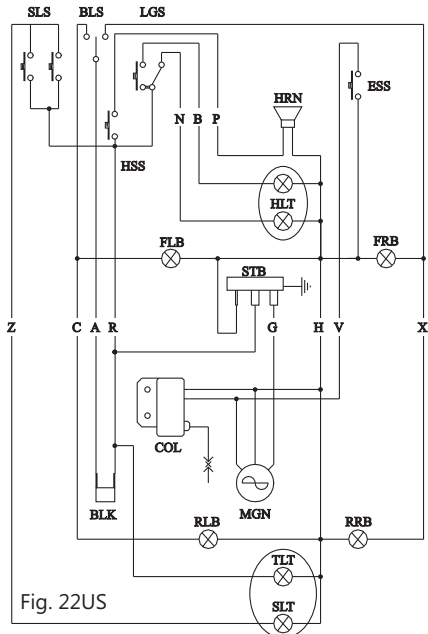

HRS Horn Switch  
 BLS Blinker Light Switch  
 ESS Engine Stop Switch  
 SLS Stop Light Switch  
 LGS Light Switch  
 HRN Horn  
 HLT Head Light  
 FLB Front Left Blinker

FRB Front Right Blinker  
 STB Stabilizer  
 COL Coil (2003)  
 MGN Magnetowheel (2002)  
 BLK Blanking Device  
 RLB Rear Light Blinker  
 RRB Rear Light Blinker

## 8 DIAGNOSIS

### *8.1 The engine does not start*

- 6 Check if the fuel is not reaching the carburetor because:
- The tank is low on fuel: place fuel tap in reserve position (lever pointing up) and then refuel;
  - The fuel tap is closed;
  - The fuel line is clogged (by an air bubble, for instance);
  - The carburetor or air filter is dirty.
- 6 Check the ignition:
- With the spark plug removed and resting with its metal portion lying on the fins of the cylinder, check whether there is a spark between the electrodes by depressing the kick starter manually.
  - Check whether the spark plug is dirty (in this case clean it thoroughly) and check whether the gap of the electrodes is correct ( $0.3 \div 0.4$  mm );
  - Check the spark plug cable and replace if it is broken or poorly insulated;
  - Check the electric wiring (see diagram fig. 22). Make sure that the ground connection between the engine and the frame is efficient.

### *8.2 The engine does not run normally*

The reason can be:

- 6 One of the reasons listed in sec. 8.1
- 6 Carbon deposit at the piston and cylinder head, at the cylinder exhaust port, in the exhaust pipe;
- 6 The spark plug or the cylinder head or the induction manifold are not tightened.

### *8.3 Fouling at the electrodes*

The reason can be a too poor carburation:

- 6 Clean the carburetor, the cylinder exhaust port, the exhaust pipe;
- 6 Tighten the spark plug, the cylinder head, the induction manifold;
- 6 Make sure that fuel is a mixture of regular fuel with 2% oil.

### *8.4 Jamming of the expanding pulley*

Disassemble and clean.

### *8.5 Jamming of the reduction unit*

Replace the V-belt.

